

This document is issued by Ningbo Begapunk Pneumatic Components Co., Ltd.

Document control: QC-2025-0512-003

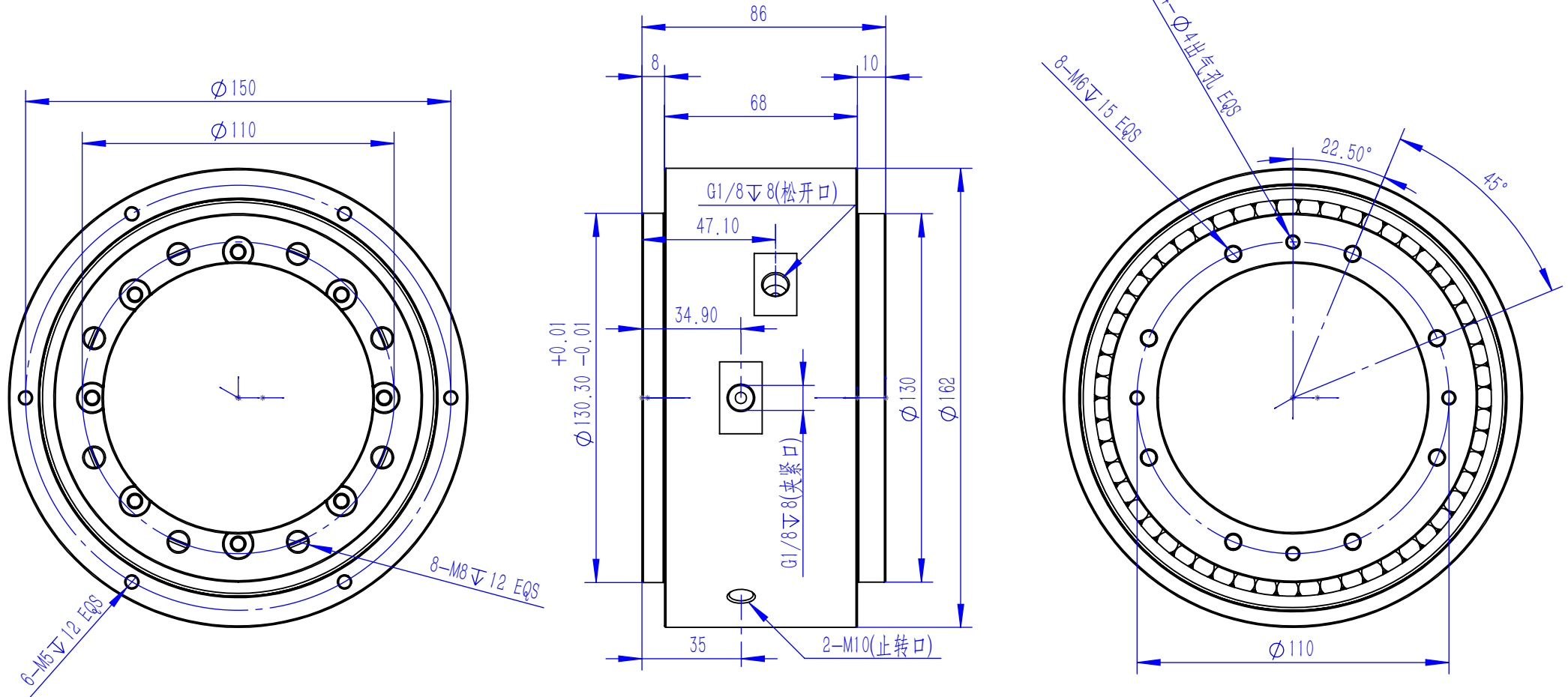

Ningbo BEGAPUNK Pneumatic Components Co., Ltd.

Medium	Air	Material	Weight	Scale	Rotary Joint
Max. Pressure	1 MPa				
Max. RPM	200	Aluminum Alloy 6061	4260g	1:2	
Temperature Range	-20° C ~ 80° C (-4° F ~ 176° F)	BEGAPUNK			BP-2P-95-0005
Surface Treatment	Anodized (Aluminum)				
Seal Material	PTFE, O-Ring	Date	2025-5-12	www.begapunk.com	

1. All sharp edges deburred 0.3 mm per ISO 13715
2. Unspecified tolerances per ISO 2768-m
3. 100% pressure tested at 1.5x rated pressure
4. Surface finish Ra 3.2 unless specified
5. Material certificates available on request