

This document is issued by Ningbo Begapunk Pneumatic Components Co., Ltd.

Document control: QC-2022-0822-003

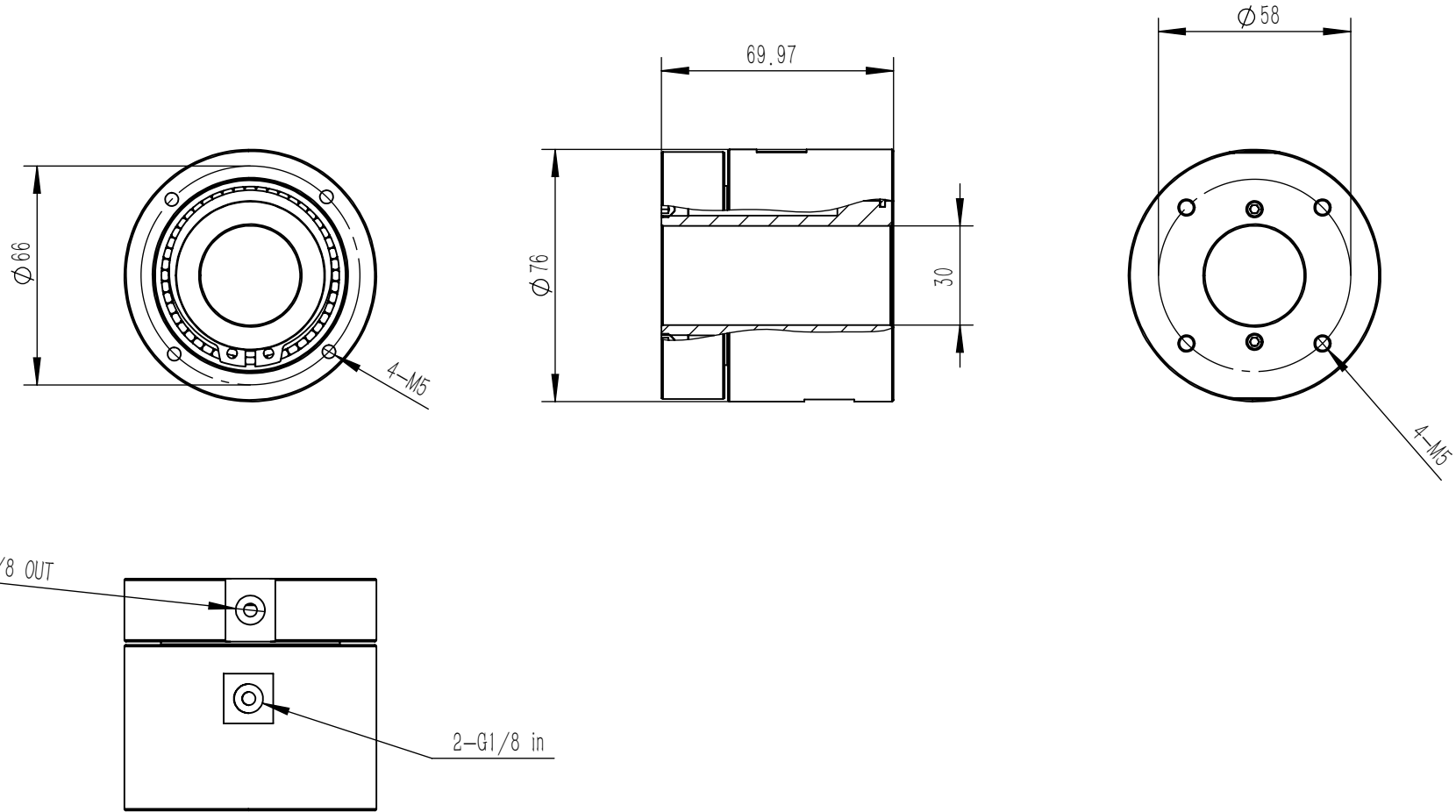

1. All sharp edges deburred 0.3 mm per ISO 13715
2. Unspecified tolerances per ISO 2768-m
3. 100% pressure tested at 1.5x rated pressure
4. Surface finish Ra 3.2 unless specified
5. Material certificates available on request

Ningbo BEGAPUNK Pneumatic Components Co., Ltd.					
Medium	Air	Material	Weight	Scale	Rotary Joint
Max. Pressure	1 MPa				
Max. RPM	150	Aluminum Alloy 6061	390g	1:1	
Temperature Range	-20° C ~ 80° C (-4° F ~ 176° F)	BEGAPUNK			BP-3P-30-0001
Surface Treatment	Anodized (Aluminum)				
Seal Material	PTFE, O-Ring	Date	2022-8-22	www.begapunk.com	